

# PACKAGE TERMINAL AIR CONDITIONER/HEAT PUMP

## Standard and Remote Applications INSTALLATION INSTRUCTIONS & OWNER'S MANUAL

C  
A  
T  
P

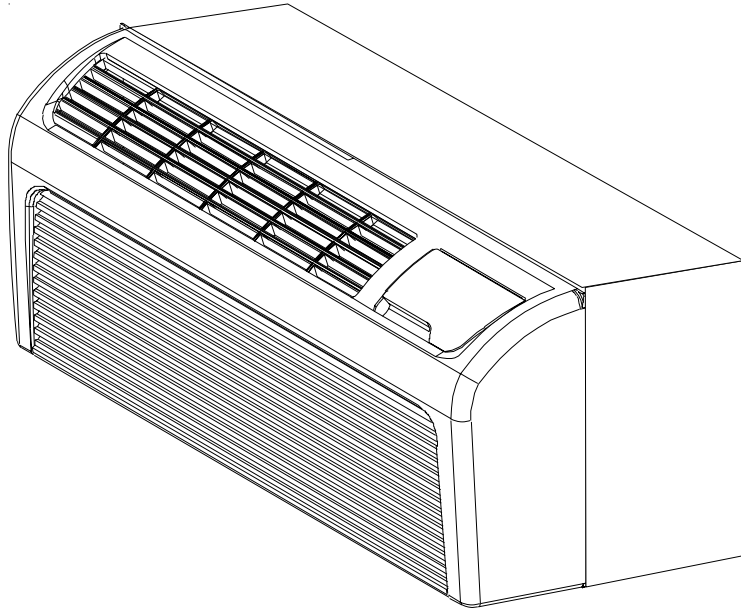

Made in USA

### ATTENTION INSTALLING PERSONNEL

As a professional installer you have an obligation to know the product better than the customer. This includes all safety precautions and related items.

Prior to actual installation, thoroughly familiarize yourself with this Instruction Manual. Pay special attention to all safety warnings. Often during installation or repair it is possible to place yourself in a position which is more hazardous than when the unit is in operation.

Remember, it is your responsibility to install the product safely and to know it well enough to be able to instruct a customer in its safe use.

Safety is a matter of common sense...a matter of thinking before acting. Most dealers have a list of specific good safety practices...follow them.

The precautions listed in this Installation Manual are intended as supplemental to existing practices. However, if there is a direct conflict between existing practices and the content of this manual, the precautions listed here take precedence.

## Contents

<b>Unit Features .....</b>	<b>3</b>
<b>General Information .....</b>	<b>4</b>
<b>Installation Instructions .....</b>	<b>5</b>
<b>Wiring .....</b>	<b>7</b>
<b>Operating Instructions .....</b>	<b>8</b>
<b>Maintenance and Cleaning .....</b>	<b>14</b>
<b>Normal Operating Sounds and Conditions .....</b>	<b>16</b>
<b>Normal Operating Sounds and Conditions .....</b>	<b>18</b>
<b>Obtaining Service .....</b>	<b>19</b>



**RECOGNIZE THIS SYMBOL AS A SAFETY PRECAUTION.**

### **IMPORTANT NOTE TO THE OWNER**

This equipment is to be serviced by professionally trained personnel only. If this equipment is improperly installed, adjusted or altered by an unqualified person, a safety hazard may result.

### **IMPORTANT NOTE TO THE SERVICER**

Read this manual and familiarize yourself with the specific items which must be adhered to before attempting to service this unit. The precautions listed in this manual should not supersede existing practices but should be considered as supplemental information.

Your warranty certificate is also supplied with the unit. Read the warranty carefully and note what is covered. Keep the warranty certificate in a safe place, so you can find it, if necessary.

*Before using this manual, check the serial plate for proper model identification.*

**THE INSTALLATION AND SERVICING OF THIS EQUIPMENT MUST BE PERFORMED BY  
QUALIFIED, EXPERIENCED TECHNICIANS ONLY.**

*Due to policy of continual product improvement, the right is reserved to  
change specifications and design without notice.*

## Unit Features

This unit has many features which are different than those found on conventional PTAC units. The servicer must be familiar with these features in order to properly service the unit.

- Automatic 3-minute compressor lockout - After the compressor cycles off, it will not restart for three minutes.
- Automatic 2<sup>nd</sup> stage electric heat - If the room temperature falls to 4.0°F below the set point temperature, the reverse cycle heat is shut off and the electric strip heat is turned on.
- Automatic freeze protection - Whenever power is supplied to the unit and the master switch is in the ON position, automatic freeze protection is active. If the unit senses temperature below 40°F, the fan motor and electric strip heat are turned on.
- Random restart delay - To help eliminate power surges after a power outage, the unit is equipped with a two to four minute random restart delay feature. Whenever the unit is plugged in with the master switch turned on and the mode switch set in the cool or heat mode, a random restart will occur. A random restart condition can be avoided by setting the mode switch in the fan only or off position before applying power to the unit.
- Fuse holder - On all 265 volt units, fuse holders are factory installed. Check for blown fuse if unit does not operate. Fuse holder is located behind the front (Figure 1). Replacement fuses may be purchased from the Parts Department or contact your sales representative for part numbers.
- Load shedding - An LS terminal has been added for load shedding operations. If at any time a switch is closed between the LS and IN terminals, the compressor and electric heater will lockout until the switch is opened.
- Transfer fan - Terminals TF(-) and TF(+) on the low voltage terminal board allow for an external (transfer) fan connection. A user-supplied relay is required and, depending upon the type used, an approved external transformer kit may be required for installation.

**NOTE:** The PTAC Wire Harness Kit (PWHK01B) is required when using either the transfer fan or load shedding option.

- Optional External Transformer - The electronic control board provides 1.8 VA power to run an optional transfer fan or remote thermostat or an energy management system. If additional power is required, the board is equipped to accept power from an external transformer. Two external 40 VA transformer accessories (one for 230/208 volt units and one for 265 volt units) are available with approved transformers. No other transformers are approved for use.
- Front mounting hole - A mounting hole is provided to give the owner the option of securing the front to the chassis. The mounting hole is located behind the air intake grille (Figure 2). The owner must supply one 1/2 inch long #8 sheet metal screw per unit. The screw must be removed before the front can be removed.

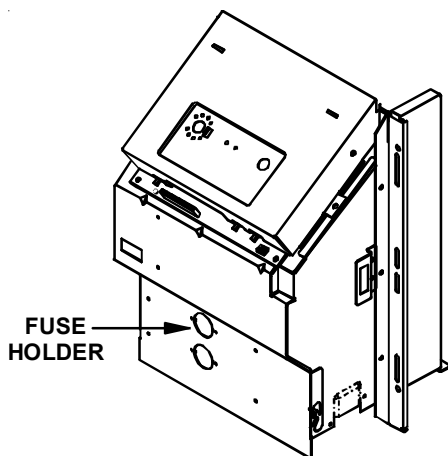

**Figure 1 - Control Panel**

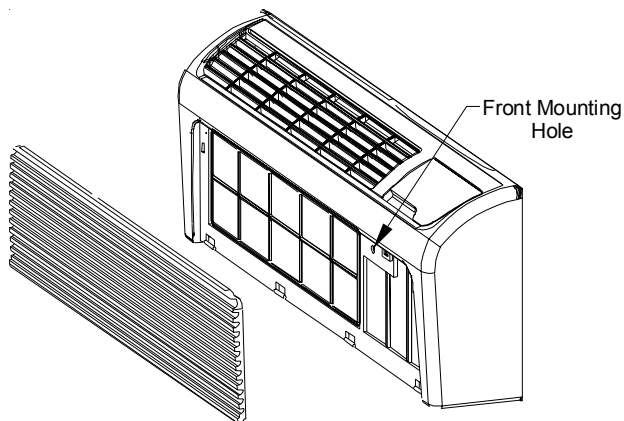

**Figure 2 - Chassis Front**

# General Information

## **TRANSPORTATION DAMAGE**

All units are securely packed in shipping containers tested according to International Safe Transit Association specifications. The carton must be checked upon arrival for external damage. If damage is found, a written request for inspection by the carrier's agent must be made immediately.

In the event of damage, the consignee must:

1. Make notation on delivery receipt of any visible damage to shipment or container.
2. Notify carrier promptly and request an inspection.
3. In case of concealed damage, carrier should be notified as soon as possible—preferably within 5 days.
4. File the claim with the following supporting documents within the 6 month statute of limitations.
  - a. Original Bill of Lading, certified copy, or indemnity bond.
  - b. Original paid freight bill or indemnity in lieu thereof.
  - c. Original invoice or certified copy thereof, showing trade and other discounts or reductions.
  - d. Copy of the inspection report issued by carrier's representative at the time damage is reported to the carrier.

The carrier is responsible for making prompt inspection of damage and for a thorough investigation of each claim. The distributor or manufacturer will not accept claims from dealers for transportation damage.

## **UNIT ACCESSORIES**

This unit is designed for through-the-wall installation in new or existing buildings. To complete the installation of this PTAC, an insulated wall sleeve and an outdoor grille (either the stamped aluminum grille or the architectural grille) are required.

The chassis and the cabinet front are shipped in one carton. Optional accessories to complete a particular installation are the following:

Optional Accessories	
Wall Sleeve Kit	Drain Kit
Leveling Legs Kit	Filter Kit
Hydronic Heat Kit	Heater Kit
Stamped Grille Kit	Subbase Kit
Deflector Grille Kit	Key Lock Kit
Extension Duct Kit	Hard Wire Kit
Wall Thermostat Kit	Main Duct Kit
Architectural Grille Kit	Power Vent Kit
Remote Escutcheon Kit	Fuse Holder Kit
External Transformer Kit	Power Switch Kit
Water or Steam Valve Kit	Wire Harness Kit
Condensate Disposal Pump Kit	Circuit Breaker Kit
Remote Temperature Sensor Kit	

**NOTE:** Consult sales literature for the appropriate voltage and amperage selections, if applicable. For additional details and illustrations of the accessories, refer to the Architect's and Engineer's Manual.

# Installation Instructions

To ensure that the unit operates safely and efficiently, it must be installed, operated and maintained according to these installation and operating instructions and all local codes and ordinances or, in their absence, with the latest edition of the National Electric Code. The proper installation of this unit is described in the following sections. Following the steps in the order presented should ensure proper installation.

## WARNING

To prevent property damage, personal injury, or death due to electrical shock, ensure the following:

- The electrical accessories are installed **only** in the pre-drilled mounting holes,

- The electrical wiring is not installed and does not hang **below** the pre-drilled mounting holes or **lie** in the unit base pan.

with the drain kit for a complete description of the installation procedure.

### SLEEVE STIFFENER AND REAR CLOSURE PANEL REMOVAL

Before the chassis can be installed in the wall sleeve, the sleeve stiffener and the rear closure panel shown in Figure 3 must be removed.

1. Remove the zigzag folded cardboard sleeve stiffener.
2. Remove the rear closure panel by folding the four flaps as indicated in Figure 4.
3. Grasping the top and bottom flanges of the rear closure panel as shown in Figure 5, the entire panel is pulled out diagonally from one side.

### DRAIN KIT INSTALLATION (*Optional Accessory*)

During normal reverse cycle heating operation, condensate water will drain out of the rear of the wall sleeve. If this water is objectionable, a drain kit should be installed. The drain kit has provisions for draining the water from either the right or left side of the sleeve externally or from the bottom of the sleeve internally. The drain kit must be installed before the outdoor grille is installed. Refer to the Installation Instructions supplied

Sleeve Stiffener

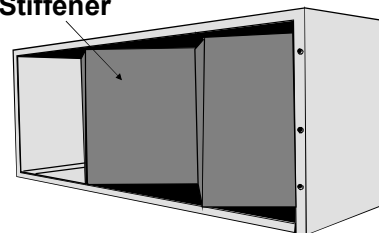

Figure 3 - Wall Sleeve with Stiffener

Rear Closure Panel

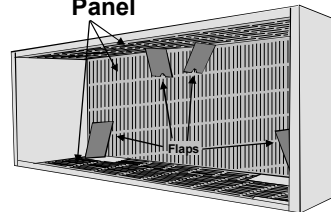

Figure 4 - Stiffener Removal

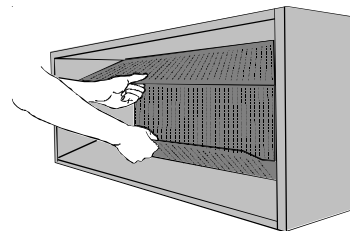

Figure 5 - Rear Enclosure Panel Removal

# Installation Instructions

## SLEEVE INSTALLATION

In order for condensate water to drain properly inside the unit, the sleeve must be installed properly:

- Level from right to left.
- A slight downward pitch from the indoor side to the outdoor side as shown in Figure 6.

Refer to the Installation Instructions supplied with the PTAC wall sleeve for a complete description of the installation procedure.

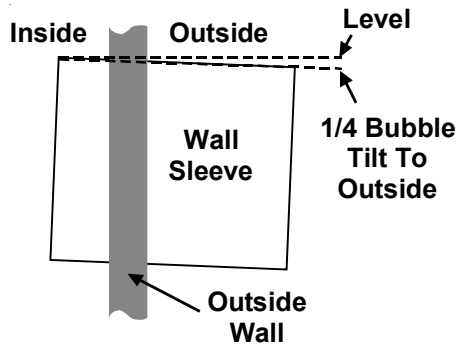

Figure 6 - Proper Sleeve Tilt

## OUTDOOR GRILLE

An outside grille must be installed to direct air flow for proper unit operation and also protect the outdoor coil. The grille must be installed before installing the chassis. Refer to the Installation Instructions supplied with the outdoor grille kit for a complete description of the installation procedure.

This model requires either a Stamped Grille Kit (Model SGK--B) or an Architectural Grille Kit (Model AGK--B). When replacing an old chassis with an existing grille or using a specialized grille in a new installation, please check with your sales representative to determine if the new chassis should be used with the non-standard specialized grille. An improper outdoor grille can decrease cooling or heating capacity, increase energy usage and shorten compressor life and possibly void the warranty.

## FRONT REMOVAL

1. Grasp the cabinet front as shown in Figure 7.

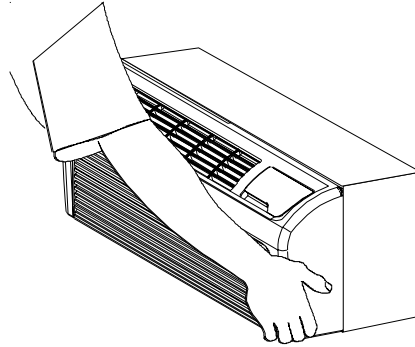

Figure 7 - Cabinet Front Removal View 1

2. Pull the bottom of the cabinet front away from the chassis until the retaining clips disengage (Figure 8).  
**NOTE:** If front is secured with screws, refer to Figure 2 for removal.

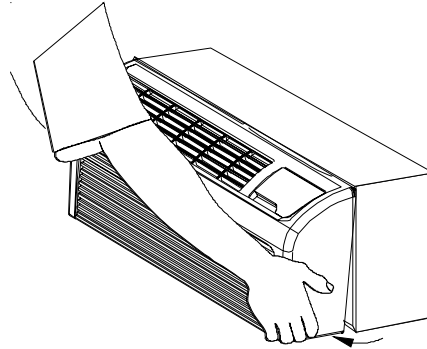

Figure 8 - Cabinet Front Removal View 2

3. Lift the cabinet front off the chassis. Reverse this procedure to reinstall the cabinet front.

## CHASSIS INSTALLATION

1. Remove the cabinet front from the chassis as described in Front Removal.
2. Insert the chassis into the wall sleeve (Figure 9).

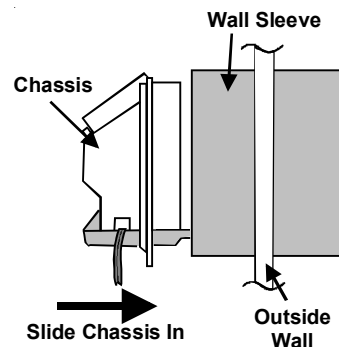

Figure 9 - Chassis Installation View 1

## Installation Instructions

- Slide the chassis into the wall sleeve until the chassis flanges contact the front edge of the wall sleeve (Figure 10).

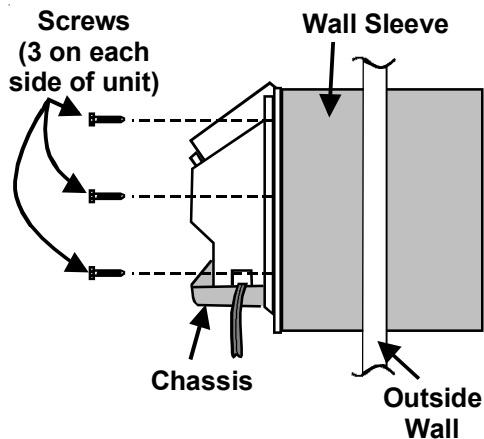

Figure 10 - Chassis Installation View 2

- Secure the chassis to the wall sleeve using *three* screws on each side of the chassis to ensure a proper seal between the chassis and the wall sleeve (Figure 10). The screws are supplied in a plastic bag attached to the power cord.

### IMPORTANT NOTES:

- The unit is equipped with a rubber grommet mounted compressor. These grommets are factory set and require no adjustment.
- If a standard subbase is used, be sure the right hand subbase cover is removed before the chassis is installed in the sleeve.
- Check the indoor and outdoor grilles for obstructions to air flow. The unit must be located where curtains, furniture, trees, or other objects do not block the air flow to and from the unit. If air is obstructed and/or deflected back into the unit, the air conditioner compressor may cycle on and off rapidly. This could damage the compressor or possibly void the warranty.

## Wiring



### WARNING

To avoid the risk of electrical shock, property damage, personal injury or death, do not service this unit without first opening all disconnects and/or removing the unit cord set plug from the wall outlet.



### CAUTION

To avoid the risk of electrical shock, property damage or personal injury, do not use an extension cord with this unit.



### CAUTION

To avoid the risk of fire, property damage or personal injury use only copper conductors.



### CAUTION

To avoid the risk of personal injury, wiring to the unit must be properly polarized and grounded.

Cord connection to a wall socket is not permitted for 265-volt units. All 265-volt units must be hard wired using the hard wire kit or make use of the plug-in receptacle in the standard subbase.



### WARNING

This air conditioner is not meant to provide unattended cooling or life support for persons or animals who are unable to react to the failure of this product.

The failure of an unattended air conditioner may result in extreme heat in the conditioned space causing overheating or death of persons or animals.

Precautions must be taken to warn of or guard against such an occurrence.

*Power Wire Harness Kit (PWHK01B)*  
See Power Wire Harness Kit Installation Instructions for proper wire orientation and location.

### *Heaterless Units*

If a heaterless unit is ordered, field provisions must be made for adding supplemental heat. Refer to the Installation Instructions supplied with the heater kit for a

# Wiring

complete description of the installation procedures. All 208/230 volt heaterless units are shipped with a 15 Amp power cord and all heaterless 265 volt units are shipped with a 20 Amp power cord.

When adding a heater kit to a heaterless unit, the power cord supplied with the heater kit must be used in place of the power cord supplied with the unit. Table 1 specifies power cord rating requirements for the various heater kits.

Power Cord Requirements		
	230/208 Volt Units	265 Volt Units
Heater Size (kW)	Power Cord Rating (amp)	Power Cord Rating (amp)
1.5	15	20
2.5	15	20
3.5	20	Not Applicable
3.7	Not Applicable	20
5.0	30	30

**Table 1 - Power Cord Requirements**

**NOTE:** Heaterless units are shipped with an auxiliary data label on the front side of the mid-partition panel. If an electric heater kit is field installed, the installer must mark the appropriate box on the label to indicate the electric heater capacity. If no heater is installed, the box labeled “None” must be marked. Refer to the unit nameplate for over current protection data.

### Voltage Measurements

Once the unit is properly wired, measure the unit supply voltage. Voltage must fall within the voltage utilization range given in Table 2.

Operating Voltage		
Unit Voltage	Voltage Utilization Range	
Rating	Minimum	Maximum
230/208	197	253
265	238	292
115	103.5	126.5

**Table 2 - Operating Voltage**

# Operating Instructions

### Users Controls

Two rotary knobs (Figure 11) controlling temperature and operational mode are located behind the control door located to the top-right of the cabinet front.

### Thermostat Setting

Turning the thermostat control clockwise will provide a cooler room temperature; turning it counterclockwise will provide a warmer room temperature. Adjusting the thermostat to the mid setting (vertical) will set the room temperature at approximately 75°F.

### Mode Switch

Table 3 describes the unit function corresponding to the various mode switch settings.

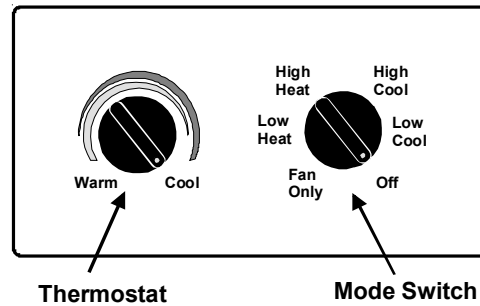
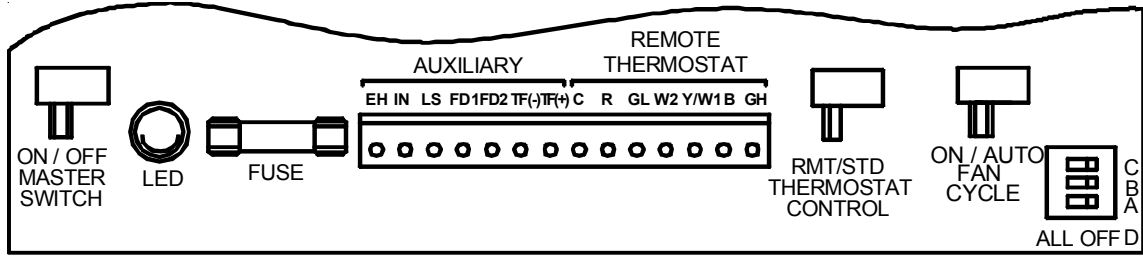

**Figure 11 - User Controls**

Mode Switch Settings	
Switch Position	Unit Function
OFF	Unit is completely off. However, open all disconnects or remove plug before servicing
FAN ONLY	Unit operates on low fan speed to circulate room air.
LOW COOL	Unit operates on the low fan speed to circulate air for cooling.
HIGH COOL	Unit operates on the high fan speed to circulate air for cooling.
LOW HEAT	Unit operates on the low fan speed to circulate air for heating.
HIGH HEAT	Unit operates on the high fan speed to circulate air for heating.

**Table 3 - Mode Switch Settings**

# Operating Instructions



**Figure 12 - Control Board User Inputs\***

**\*NOTE:** The PTAC Wire Harness Kit (PWHK01B) is required for the auxiliary or remote thermostat options.

### *Additional Control Inputs*

The control inputs shown in Figure 12 provide additional unit control and features. To access these control inputs, the cabinet front must be removed (see Front Removal).

### *Master Switch*

The master switch disconnects power to all of the system components. When this switch is in the off position, the compressor, fan motor, reversing valve, and electric resistance heater will all be de-energized.



## WARNING

To prevent property damage, personal injury or death due to electrical shock, unplug the unit at the wall outlet or turn off power at the fuse box or circuit breaker before servicing the unit. Line voltage will be present at the control board, terminals L1 and L2, whenever power is applied to the unit regardless of the master switch position.

### *Remote/Standard Switch*

The remote/standard switch is used to change the control of the unit from the standard on board controls in the standard mode, to a remote wall mounted thermostat in the remote mode. For remote control operation refer to Remote Operation section.

### *Fan Cycle Switch*

The fan cycle switch sets the operational mode of the fan. In the ON position, the fan will run continuously whenever the unit is in the heat or cool mode. In the AUTO position, the fan will cycle on and off with the compressor or electric heater when the unit is in the cool or heat mode.

### *Remote Control Inputs*

The C, R, GL, W2, Y/W1, B, and GH terminals provide control inputs for a “manufacturer-approved” remote wall mounted thermostat. For remote control operation refer to Remote Operation section.

### *Front Desk Control*

The FD1 and FD2 terminals provide control inputs for a front desk switch. Shorting across these two terminals will disable unit operation. The only control function which will remain active when these terminals are shorted is freeze protection. Any switch which will produce a short circuit across these two terminals can be used as a front desk switch. The contact resistance of the switch, when closed, must be less than 200 ohms for the front desk feature to operate properly. Table 4 shows the maximum wire length and corresponding gage size for installation of a front desk switch. Figure 13 shows a wiring schematic for connecting the front desk switch to the unit.

Maximum Wire Length	
Wire Size (AWG)	Maximum Length Allowed
#24	400 ft
#22	600 ft
#20	900 ft
#18	1500 ft
#16	2000 ft

**Table 4 - Maximum Wire Length for Front Desk Switch**

# Operating Instructions

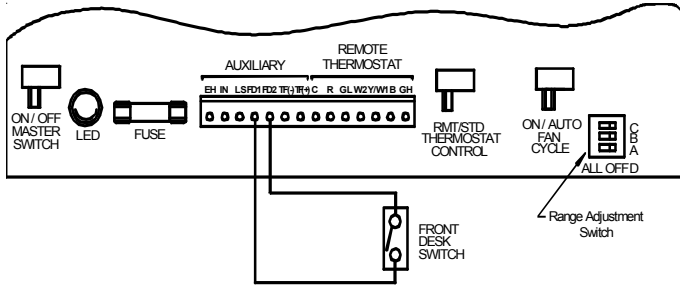

**Figure 13 - Front Desk Switch Wiring Schematic**

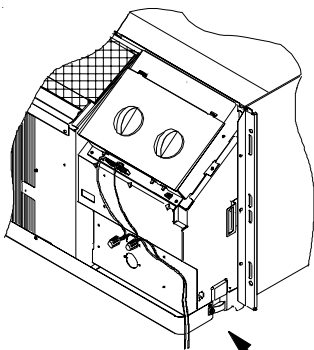

No holes are permitted in chassis basepan or wallsleeve when routing low voltage wire.

**Figure 14 - Low Voltage Wires Routing**

## Temperature Limiter

The temperature limiting feature can reduce energy costs by controlling the maximum temperature available in heating and the minimum temperature available in cooling. While approximate temperature settings are shown in the following table, actual room temperature may vary slightly.

The temperature limits are set by selecting the proper switches on the range adjustment switch (Figure 13). Table 5 shows the high and low end temperatures corresponding to the various limiter switches. Since these temperatures correspond to the thermistor sensor, actual room temperatures may vary depending on the room heating/cooling load. For example, if the limiter switch B is ON in Table 5, the coolest setting in the

cooling mode will be 68°F and the warmest setting in the heating mode will be 76°F.

Position	Cool (°F)	Heat (°F)
A	70-78	65-73
B	68-81	68-76
C	66-83	61-78
D	63-88	58-83

**Table 5 - Temperature Limiter Settings**

After determining the temperature limits desired, set the limiter as follows:

1. Remove the front cabinet (see Front Removal) to allow access to the control panel.
2. Slide the appropriate switch to the ON position (left). **NOTE:** Only one switch can be ON at a time. If all switches are OFF, the thermostat is at full operating range.
3. Replace the front cabinet.

**NOTE:** To achieve maximum efficiency, it may be necessary to change the temperature limiter switch seasonally.

## On Board Diagnostics

An LED is located on the control board. During normal operation the LED will flash once every six (6) seconds. If the LED flashes twice every 6 seconds, the fuse is open. To replace the fuse. Pop out the current fuse holder, flip it over, and reinsert the provided spare fuse. If the LED is flashing more than 2 times every 6 seconds, contact a servicer.

FLASHES	SITUATION	CORRECTIVE ACTION
1 Flash	Control Ok	Board OK
2 Flashes	24 VAC Fuse Blown	Replace fuse
3 Flashes	Indoor Coil Thermistor Failure	Replace Indoor Coil Thermistor
4 Flashes	Mode Switch Failure	Replace Board
5 Flashes	Thermostat Control	Replace Board
6 Flashes	Bad Thermostat Input Failure	Replace Thermostat or Correct Wiring
8 Flashes	Indoor Ambient Thermistor Failure	Replace Thermistor

**Table 6 - Diagnostic Codes**

# Operating Instructions

## VENT CONTROL

The vent control allows outside air to be drawn into the conditioned area. This outside air can provide ventilation when the blower is operating, but it will increase the heating or cooling load and operating costs.

To obtain access to the vent control:

1. Remove the cabinet front (see Front Removal).
2. Remove the shipping screw (if installed) from the vent door.
3. Remove the label (if present) from over the vent control lever on the left side of the chassis as shown in Figure 15. Remove the vent door shipping screw.

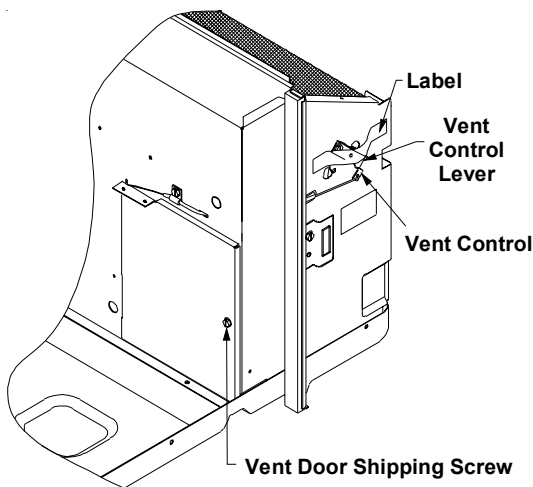

**Figure 15 - Vent Control Lever**

4. Rotate the vent control lever to either open or close the damper as shown in Figure 16.

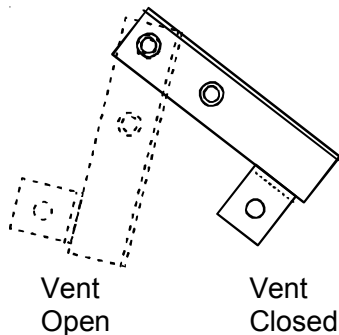

**Figure 16 - Vent Door Lever Positions**

## Hydronic Heat Installations

To avoid the risk of freezing the steam or water coil during prolonged shut down periods, the vent door must be left closed when the outdoor temperature might fall below freezing.

## Air Discharge Grille

The discharge grille can be adjusted to expel air at either a 15° or 40° angle as shown in Figure 17.

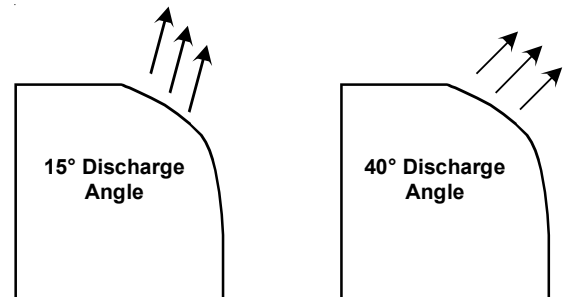

**Figure 17 - Discharge Grille Orientation Options**

Use the following procedure to change the angle of the discharge air flow:

1. Remove the front cabinet (see Front Removal).
2. Position the front so that the backside is accessible as shown in Figure 18.

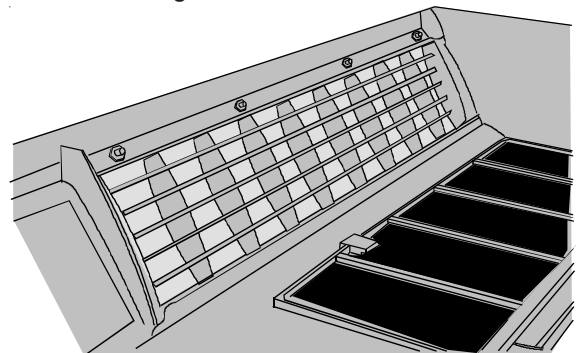

**Figure 18 - Discharge Air Flow**

3. Remove the four nuts which secure the discharge air grille to the cabinet front as shown in Figure 19.

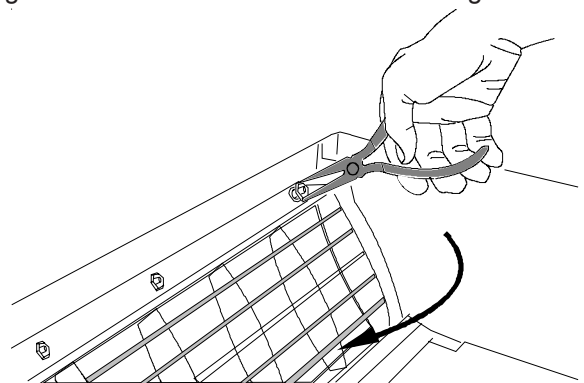

**Figure 19 - Discharge Air Flow Grille Removal**

4. Rotate the grille 180° clockwise.

# Operating Instructions

- Reinstall the nuts securing the discharge air grille to the cabinet front. Reinstall the cabinet front on the unit.

### Remote Thermostat

To operate this unit with a “manufacturer-approved” remote thermostat, the Standard/Remote Control switch shown in Figure 12 must be set to the remote position. When in the remote mode, the unit will only respond to the thermostat inputs (terminal strip positions GL (or GH), W2, Y/W1, and B shown in Figure 12). The mode switch and thermostat used for standard operation will be automatically overridden.

**NOTE:** In remote mode, the 3-minute compressor time delay, the random restart feature and the freeze protection feature are all active (see *Unit Features* section).

### Thermostat Location

This unit is designed to be operated with remote wall mounted thermostats. For further information on thermostats approved for use with this unit, contact your sales representative.

For best performance results, the thermostat should be located approximately five feet above the floor on a vibration free, inside wall in an area with good air circulation.

**Do not** install the thermostat where it may be affected by the following:

- Dead spots behind doors, in corners or under cabinets
- Hot or cold drafts from air ducts
- Radiant heat from the sun, appliances, or fireplaces
- Concealed pipes and chimneys
- Unheated (uncooled) areas behind the thermostat, such as an outside walls

Consult the instruction sheet packaged with the thermostat for further details on mounting and operation.

### Remote Thermostat Operation

Approved thermostats vary slightly in construction and, with few exceptions, are operated similarly. The following operational description pertains to approved nonprogrammable thermostats that energize G in Heat and Cool mode.

### HEAT/OFF/COOL Switch

- OFF - cooling and heating functions are defeated.
- HEAT - the selected room temperature is maintained by cycling either in the heat pump mode or electric strip heat. A PTH unit is switched from the heat pump mode to electric strip heat when the coil temperature is 20°F or when the heat pump cannot keep up with the heating load and a two stage thermostat is used.
- COOL - the selected room temperature is maintained by cycling the air conditioner.

Table 7 summarizes the thermostat input combinations and the respective unit functions. Figure 20 and 21 show wiring schematics for heat pump and straight cool units with electric resistance heat, respectively.

Unit Function	Heat Pump Thermostat Input	Electric Heat Thermostat Input
	R Terminal to:	R Terminal to:
OFF	NONE	NONE
HEAT Stage 1	GL*, Y/W1, B	GL*, Y/W1, B or GL*, W2
Stage 2	GL*, W2	n/a
COOL	GL*, Y/W1	GL*, Y/W1

\*or GH depending on speed required.

**Table 7 - Remote Control Inputs**

**NOTE:** The PTAC Wire Harness Kit (PWHK01B) is required for remote thermostat options.

### ADDITIONAL NOTES:

- For heat pump operation, a room thermostat with a “B” (heating changeover) terminal is required. This will mean that some “auto changeover” thermostats cannot be used, as many of them either do not have a “B” terminal, or else energize the “B” terminal continuously when in the “auto” position.
- The maximum power consumption of any thermostat is 1.2 watts.  
If a transfer fan/relay is connected, the total power consumption of all remote accessories must not exceed 1.2 watts or an optional field transformer must be used.
- Additional wiring should be run for future changeover to Heat Pump or thermostat options.
- Run 6 to 8 wires during initial installation. Tape or cap off any unused wires.

# Operating Instructions

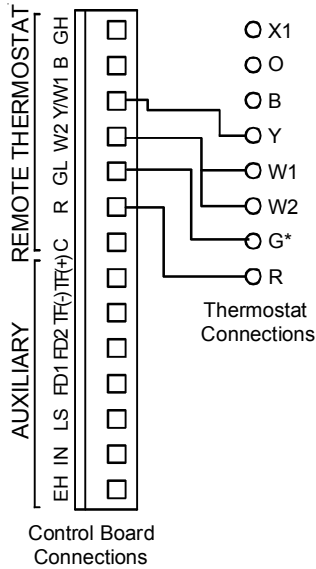

**Figure 20 - Wiring Schematic for Straight Cool Unit**

**\*NOTE:** For high speed fan operation, connect “G” to “GH”.

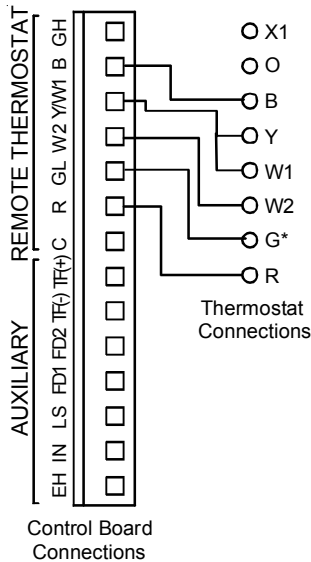

**Figure 21 - Wiring Schematic for Remote Heat Pump**

**\*NOTE:** For high speed fan operation, connect “G” to “GH”.

Table 8 shows the maximum wire length and corresponding gage size for installation of a remote thermostat.

## Remote Temperature Sensing

With control functions remaining at the unit, the remote temperature sensing feature is a unique accessory capable of providing accurate sensing of room temperature from a central location, separate from the unit.

The remote temperature sensor (Figure 22) is connected to the unit using two low voltage wires (Figure 23). Refer to the Installation Instructions supplied with the Remote Temperature Sensor kit for further information.

The Remote/Standard Thermostat Control switch must be in the STANDARD position when using the Remote Temperature Sensor kit.

Maximum Wire Length	
Wire Size (AWG)	Maximum Length Allowed
#24	400 ft
#22	600 ft
#20	900 ft
#18	1500 ft
#16	2000 ft

**Table 8 - Maximum Wire Length for Remote Control Connection**

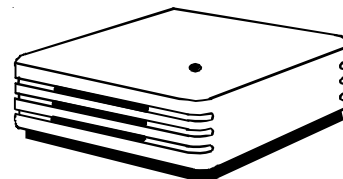

**Figure 22 - Remote Temperature Sensor**

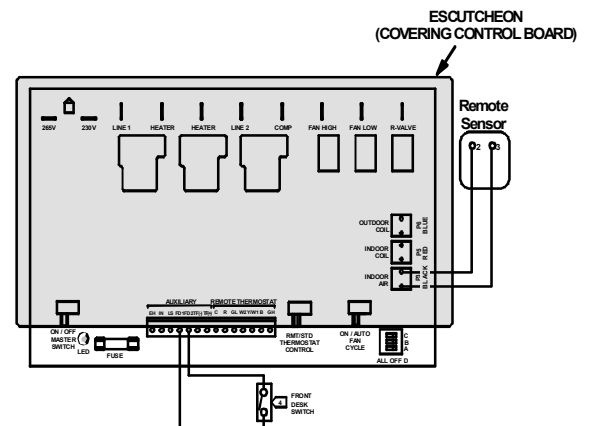

**Figure 23 - Remote Temperature Sensor Wiring**

## Maintenance and Cleaning

**NOTE:** The compressor does not require maintenance. It is hermetically sealed, permanently lubricated.

### **WARNING**

To prevent property damage, personal injury or death due to electrical shock, disconnect the electrical power supply before cleaning this unit.

### **CAUTION**

To avoid the risk of electrical shock, property damage, or personal injury clean air filters and coils regularly. Clogged or severely restricted filters or coils reduce airflow which can cause drastic efficiency loss as well as severe component damage to compressors, electric heater or fan motor. In extreme cases, clogged filters and/or coils may create a fire hazard and will void warranty.

### **CAUTION**

Some local conditions and environments can cause fungi and other material to grow inside the PTAC unit. This material when dried, as well as other foreign material, similar to dryer lint in your clothes dryer, are fire hazards. Be sure to thoroughly check and clean the unit's coils, blower wheel and basepan per the instructions contained in the manual.

# Maintenance and Cleaning

## MONTHLY MAINTENANCE AND CLEANING

### Intake Air Filter

To properly maintain the operational performance of your PTAC unit, it is **extremely** important that the inlet air filter be cleaned once per month or more often if operated in dusty or dirty locations or conditions. The intake air filter is constructed of durable polypropylene. The "air intake" air filter can be easily inserted into the cabinet front using the cabinet filter guides. The intake air grille swings out for easy access to the filter. Before cleaning the intake filter, turn the unit off by setting the mode switch to the OFF position. Filter should be cleaned as required.

The following procedure is used to remove the intake filter:

1. Open the intake grille by grasping the top intake louver.
2. Pull the intake grille open.
3. Slide filter upward and remove.
4. Clean filter with vacuum or with running water.

Reverse this procedure to reinstall the filter.

**NOTE:** Available accessory filter kits are FK10B (air intake filter - 10 per pack) and CFK10B (charcoal filter - 10 per pack). The charcoal filters will greatly improve the quality of the air by absorbing odors from tobacco smoke, mold, mildew, etc. Both filters are permanent and cleanable. Contact your sales person for details.

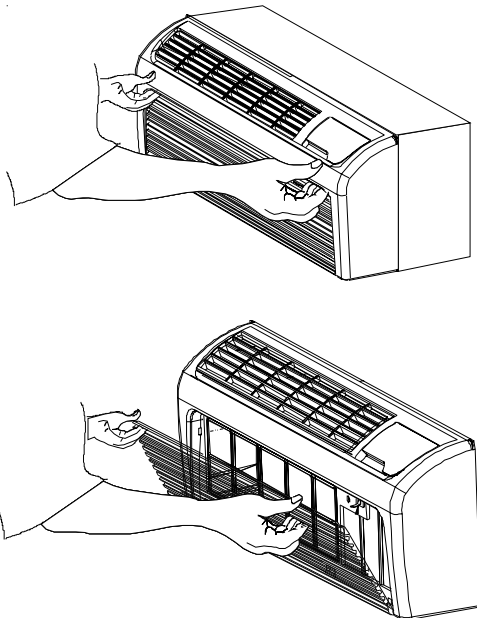

**Intake Filter Removal**

### Vent Screen

Before cleaning the vent screen, disconnect power to the unit by unplugging the power cord at the wall outlet or subbase, or disconnect power at the fuse box or circuit breaker. **If unit is operated with vent door closed**, the vent screen does not need to be cleaned.

1. Remove the cabinet front as described in Front Removal.
2. Remove the six screws securing the chassis to the wall sleeve.
3. Slide the chassis out of the wall sleeve far enough so that the vent screen is accessible.
4. Remove the three screws securing the vent mesh screen to the partition panel.
5. Clean and replace the vent screen, slide the chassis back into the wall sleeve, secure it in place with six screws and reinstall the front cabinet.

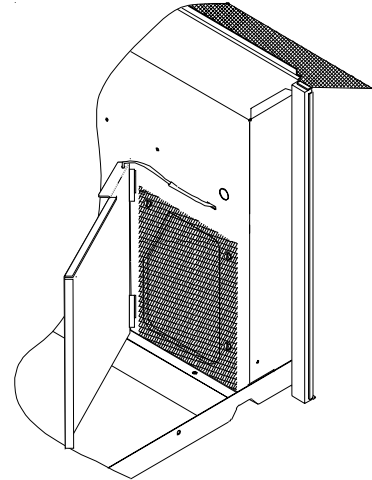

**Vent - (Left Side Unit)**

### Cabinet Front

The cabinet front and discharge air grille can be cleaned with a water dampened cloth. Under no circumstances should hydrocarbon-based cleaners (e.g. acetone, benzene, naphtha gasoline, etc.) be used to clean the front or air grilles. Use care when cleaning the control area.

# Maintenance and Cleaning

## YEARLY MAINTENANCE AND CLEANING

**NOTE:** Use a mild **biodegradable** detergent such as Simple Green™ when cleaning the unit. Special care must be taken to protect the unit's control board and other electrical components from getting any water on them while cleaning. The use of harsh or caustic cleaning agents or materials such as bleach or coil cleaners that are not designed for PTAC products will cause damage or deterioration of the aluminum fin or coil material and is not recommended. Care must be taken not to bend the aluminum fin stock.

### *Routine Scheduled Maintenance*

To achieve continuing top performance and high efficiency, establish a "once a year" cleaning/inspection schedule for the unit. Take the unit out of the sleeve and thoroughly clean and rinse. Be sure to include in the yearly cleaning the evaporator coils, and condenser coils, basepan, and drain passages. Scheduled maintenance can be accomplished by either local maintenance staff or by an authorized servicer. They must follow the instructions described in this manual.

### *Adverse Operating Conditions Maintenance*

Units operating in dusty or corrosive locations; i.e. dusty construction site or sea coast, must be cleaned more often. A minimum of four (4) times a year will maintain proper operational conditions and protect unit components.

### *Wall Sleeve*

Clean the wall sleeve while cleaning the unit. The caulking around the sleeve should be checked to make sure that any potential air and water openings around the sleeve are properly sealed. The wall sleeve's level should also be rechecked. Proper leveling for most installations are a ¼ bubble tilt to the outside and level from right to left. Contact your sales person for detailed maintenance or cleaning instructions.

### *Basepan and Condenser Coil*



#### **CAUTION**

Do not use commercial grade coil cleaners. Some of these cleaners may contain Ethylene Diamine Tetracetic Acid (EDTA) which can shorten the life of the condenser coil.

To disconnect power, either unplug the power cord at the wall outlet or subbase, or disconnect power at the fuse box or circuit breaker.

1. Create a water-tight seal by tightly covering the entire control panel area and fan motor with plastic. Creating this seal prevents water from entering the control area or the fan motor and damaging the unit.
2. Spray condenser coil and basepan down with water. Next spray a mild **biodegradable** detergent such as Simple Green™ onto the condenser coil and basepan. Let set for five (5) minutes.
3. Rinse condenser coil and basepan with water again. **NOTE:** Ensure water pressure is no higher than that of an ordinary garden hose and the water temperature no higher than 120°F.
4. Tilt the non-compressor side of the unit up no higher than 45 degrees and allow water to drain out the other side of the unit.
5. Remove excess water left in the basepan by wiping the basepan with a dry cloth.
6. Remove the water-tight seal from the motor and control panel area.
7. Reinstall unit back into wall sleeve.
8. Allow unit to dry for 24 hours before reapplying power. When power is reapplied test unit for proper operation.
9. Place a non-acidic algaecide in the basepan to inhibit bacteria growth. Ensure the algaecide is compatible with wet coil operation and is not corrosive to the coil.



#### **CAUTION**

High pressure and high temperature cleaning is not recommended. Doing so could damage the aluminum fin stock and electrical components.

Before cleaning the basepan and condenser coil, turn OFF unit mode switch and disconnect power to the unit.

# Maintenance and Cleaning

## Clearance Check

Clearances around the unit should also be checked to make sure that the intake air and discharge air paths have not become blocked or restricted. A minimum of eight inches clearance is needed from unit to furniture, beds, or other objects for proper operation. Restricted discharge or intake air will reduce the unit's operational performance ( see graph: *Energy Cost Multiplier Caused by Dirty Filter or Evaporator Coil*) In severe airflow restrictions damage can occur to unit components such as the compressor, electric heater or fan motor.

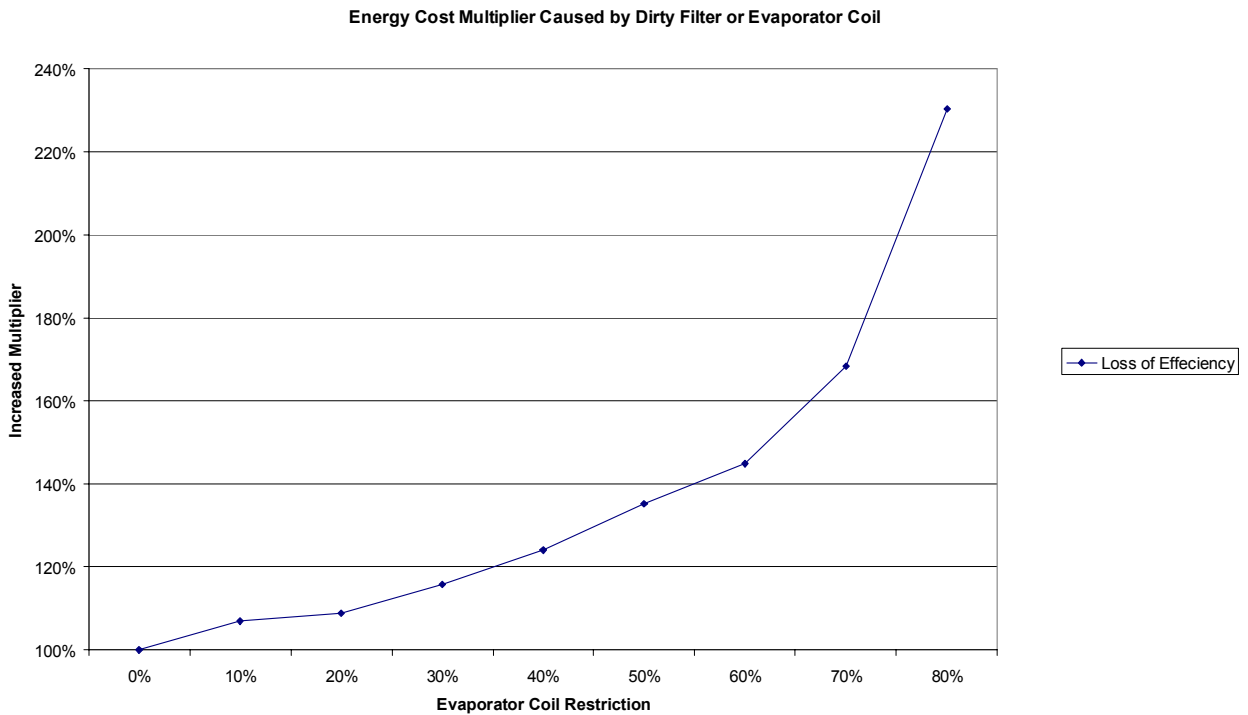

## Normal Operating Sounds and Conditions

---

- ▣ *Water trickling sounds*  
Water is picked up and distributed over the coil. This improves the efficiency and helps with water removal.
  
- ▣ *Water dripping*  
Water will collect in the base pan during high humidity days. This can cause overflow and drip from the outside of the unit.
  
- ▣ *Air sounds*  
The fan cycle switch sets the operational mode of the fan in the ON position. The fan will run continuously whenever power is applied in this mode. In the AUTO position, the fan will cycle on and off with the compressor or electric heater.
  
- ▣ *Starting delay*  
You may notice a few minutes delay in the starting if you try to restart the unit too soon after turning it off or if you adjust the thermostat right after the compressor has shut off. This is due to a built in delay to protect the compressor.

## Obtaining Service

---

In the event this unit requires repair or servicing beyond what is covered in this manual, contact an authorized service organization.

To obtain an authorized servicer, contact your sales representative or agency.

